

Bruner, Cooper & Zuck, Inc.

Kevan J. Cooper, P.E., P.L.S.
Gregory C. Peterson, P.E., S.E.



Civil Engineers
Structural Engineers
Land Surveyors

ADDENDUM NO. 5
TO THE
PLANS AND SPECIFICATIONS FOR
WELL NO. 4
VILLAGE OF PRINCEVILLE, ILLINOIS

OCTOBER 26, 2010

NOTE: Wherein this Addendum conflicts with the "Plans and Specifications", dated May 15, 2009, this Addendum shall govern.

SPECIFICATIONS

Section 11260 – Chlorination System: This section was inadvertently omitted from the specification. Due to the bids being due in only a couple of days, the attached manufacturer's data sheets will have to do as the specification to allow you to get pricing. The products can be found on-line.

The pump is a Sta-Rite general purpose centrifugal pump, Model JHE-63HL, one horsepower, 115 Volt, 60 Hertz, with the rotated volute, or equal.

The Chlorinator is a Regal Model 210, or equal.

The Scales are a Scaleton Industries, Ltd. Model 5305 Hydraulic Single Cylinder Scale, or equal.

The remaining components of the chlorination system are to be new, best quality, and made for the intended use.

PLANS

No Changes.

NOTE: Bidders shall note in writing on the Bid Form that this Addendum has been taken into consideration, identifying same as Addendum No. 5, dated October 26, 2010.

BIDS ARE DUE: Friday, October 29, 2010 at 10:00 A.M. Central Time.



general purpose centrifugal pumps

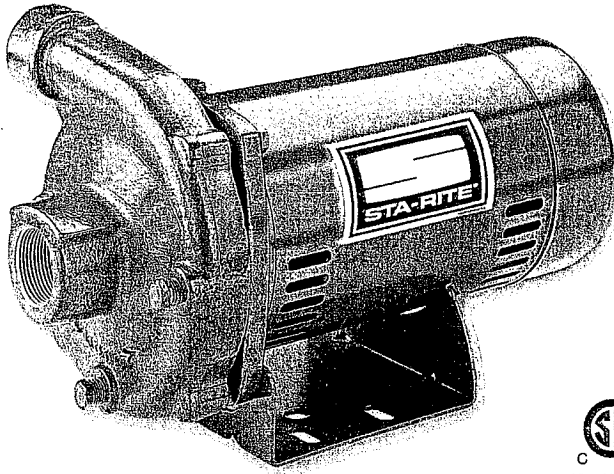

The J/JB Series Pumps have a heavy-duty cast iron construction and are offered in high and medium head models, with Noryl® or silicon bronze impeller.

APPLICATIONS

- Water systems and sprinkling... for homes, farms and industry.

SPECIFICATIONS

- Body and Seal Plate** – Close-grained cast iron
- Base** – Steel 12 gauge
- Impeller – J Series** – Noryl
- Impeller – JB Series** – Silicon bronze
- Shaft** – 416 stainless steel
- Mechanical Seal** – Carbon/ceramic, Buna-N

J/JB SERIES

FEATURES

1/3 through 2-1/2 HP – High head and medium head models, with heavy-duty motors, easy service design and four-position discharge.

Drain Port – Provided for easy winterizing.

Medium Head Models – Deliver up to 110' of head with capacities to 140 GPM.

High Head Models – Deliver up to 140' of head with capacities to 90 GPM.

Easy Serviceability – All models include replaceable wear ring and feature back pull-out design.

J Series with Noryl Impellers – Abrasion-resistant for normal applications with working temperatures to 140°F.

JB Series with Silicon Bronze – JB pumps equipped with shaft seals rated for temperatures to 225°F.

JHE-63HL 110V 1hp 2mpf + 6000h

ORDERING INFORMATION

HIGH HEAD							
Catalog Number		HP	Pipe Tapping Sizes		Motor Voltage	Phase	Approx. Wt. Lbs.
Noryl® Impeller	Silicon Bronze Impeller		Suct.	Disch.			
JHB	JBHB	1/3	1-1/4"	1"	115	1	38
JHC	JBHC	1/2	1-1/4"	1"	115/230	1	39
JHC3	JBHC3		1-1/4"	1"	208-230/460	3	39
JHD	JBHD	3/4	1-1/4"	1"	115/230	1	42
JHD3	JBHD3		1-1/4"	1"	208-230/460	3	42
JHE	JBHE	1	1-1/4"	1"	115/230	1	45
JHE3	JBHE3		1-1/4"	1"	208-230/460	3	45
JHF	JBHF	1-1/2	1-1/4"	1"	115/230	1	49
JHF3	JBHF3		1-1/4"	1"	208-230/460	3	49
JHG	JBHG	2	1-1/2"	1-1/4"	115/230	1	69
JHG3	JBHG3		1-1/2"	1-1/4"	208-230/460	3	69
JHHG	JBHHG	2-1/2	2"	1-1/2"	115/230	1	74
JHHG3	JBHHG3		2"	1-1/2"	208-230/460	3	74

MEDIUM HEAD							
Catalog Number		HP	Pipe Tapping Sizes		Motor Voltage	Phase	Approx. Wt. Lbs.
Noryl® Impeller	Silicon Bronze Impeller		Suct.	Disch.			
JMB	JBMB	1/3	1-1/4"	1"	115	1	38
JMC	JBMC	1/2	1-1/4"	1"	115/230	1	39
JMC3	JBMC3		1-1/4"	1"	208-230/460	3	39
JMD	JBMD	3/4	1-1/4"	1"	115/230	1	42
JMD3	JBMD3		1-1/4"	1"	208-230/460	3	42
JME	JBME	1	1-1/2"	1-1/4"	115/230	1	43
JME3	JBME3		1-1/2"	1-1/4"	208-230/460	3	43
JMF	JBMF	1-1/2	1-1/2"	1-1/4"	115/230	1	54
JMF3	JBMF3		1-1/2"	1-1/4"	208-230/460	3	54
JMG	JBMG	2	1-1/2"	1-1/4"	115/230	1	66
JMG3	JBMG3		1-1/2"	1-1/4"	208-230/460	3	66
—	JBMMG	2-1/2	2"	1-1/2"	115/230	1	74
—	JBMMG3		2"	1-1/2"	208-230/460	3	74

Noryl® is a registered trademark of General Electric Co. PRO-Source™ is a trademark of Pentair Water. In order to provide the best products possible, specifications are subject to change.

STA-RITE®

OWNER'S MANUAL

INSTALLATION AND OPERATING INSTRUCTIONS
REPAIR PARTS LIST

60 CYCLE "J" and "JB" SERIES CENTRIFUGAL PUMP

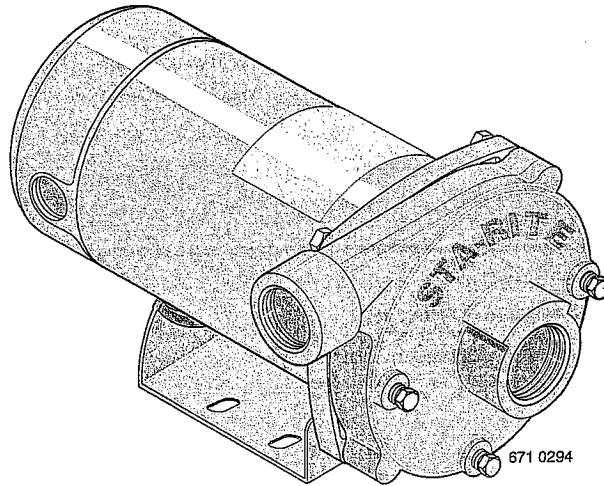

115-230

MODELS

HP	MEDIUM HEAD MODELS				HIGH HEAD MODELS			
1/3	JBMB-56S	-	JMB-56L	-	JBHB-61S	-	JHB-61HL	-
1/2	JBMC-56S	JBMC3-56S	JMC-56L	JMC3-56	JBHC-61S	JBHC3-61S	JHC-61HL	JHC3-61H
3/4	JBMD-57S	JBMD3-57S	JMD-57L	JMD3-57	JBHD-62S	JBHD3-62S	JHD-62HL	JHD3-62H
1	JBME-58S	JBME3-58S	JME-58L	JME3-58	JBHE-63S	JBHE3-63S	<u>JHE-63HL</u>	JHE3-63H
1-1/2	JBMF-40S	JBMF3-40S	JMF-40L	JMF3-40	JBHF-51S	JBHF3-51S	JHF-51HL	JHF3-51H
2	JBMG-41S	JBMG3-41S	JMG-41L	JMG3-41	JBHG-52S	JBHG3-52S	JHG-52HL	JHG3-52H
2-1/2	JBMMG-59S	JBMMG3-59S	-	-	JBHGG-53S	JBHGG3-53S	JHGG-53HL	JHGG3-53H

110 V ac 1 hp.

STA-RITE INDUSTRIES, INC., DELAVAN, WISCONSIN 53115

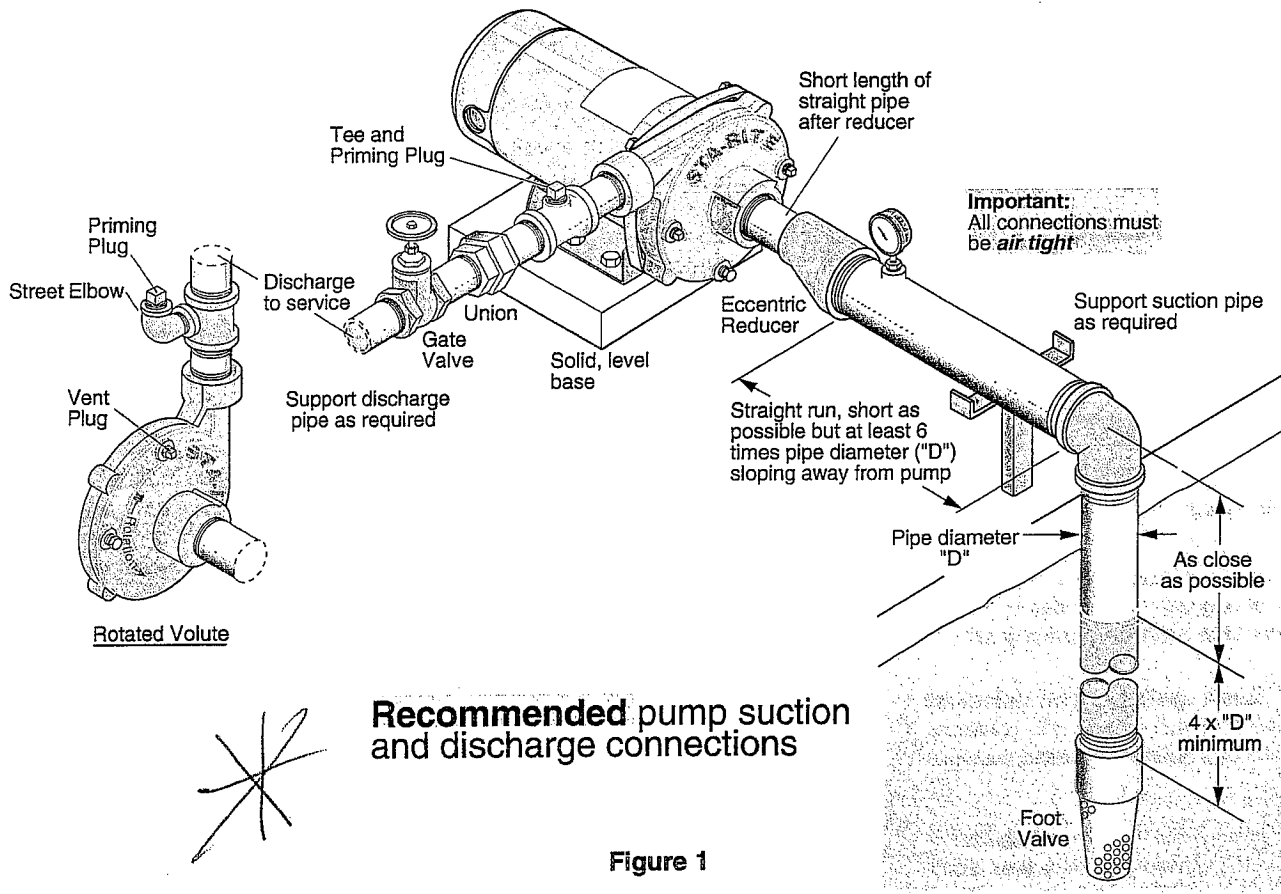

Figure 1

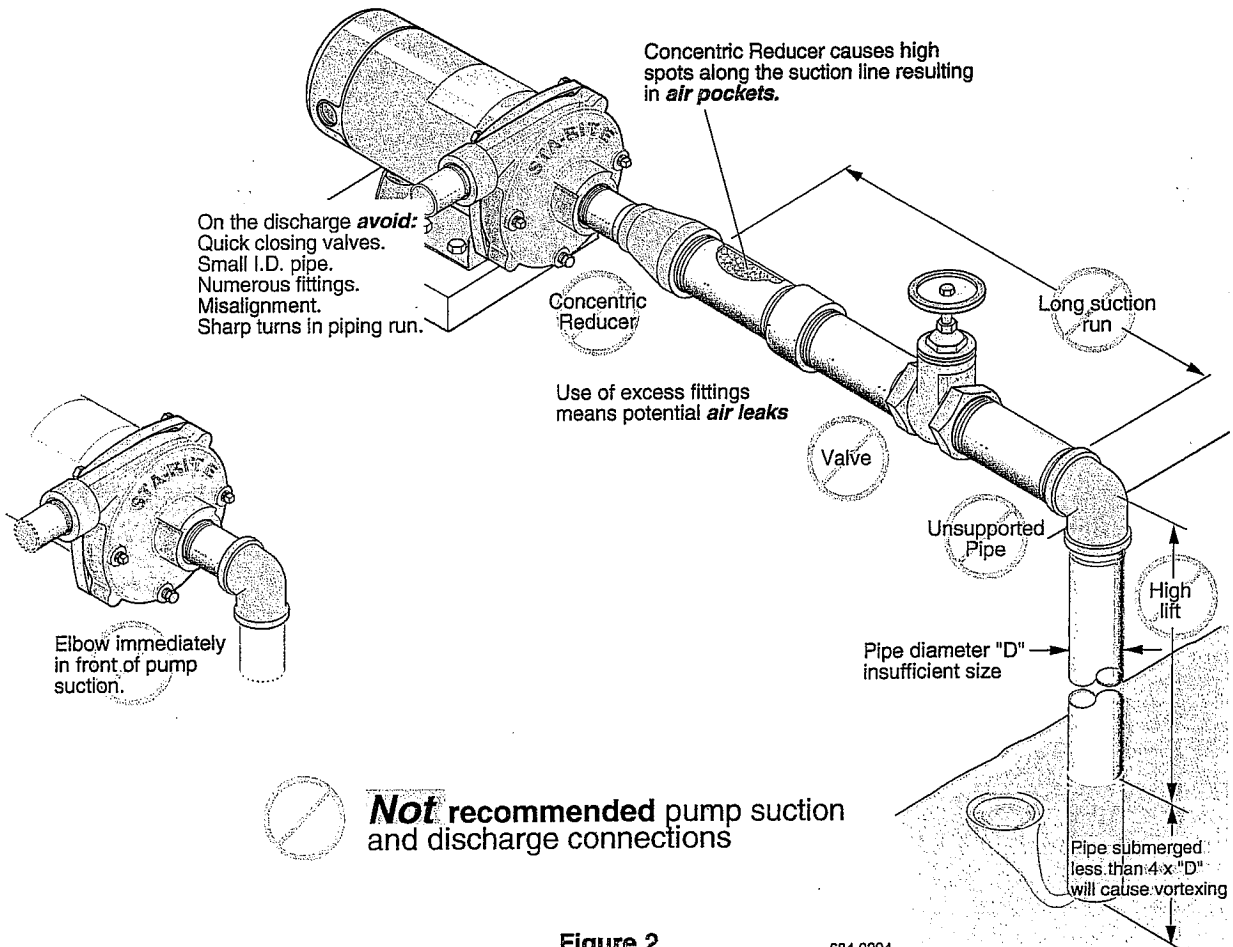

Figure 2

684 0294

REGAL GAS CHLORINATOR

The REGAL Model 210 Chlorinator is a vacuum-operated, solution feed type, designed for mounting directly on a chlorine cylinder valve by means of a positive heavy duty yoke clamp. The chlorine flow rate is manually adjusted and is regulated by a spring opposed diaphragm regulator which also contains the safety shut-off valve. Vacuum is provided by a highly efficient water operated ejector which is close coupled with the chlorine solution diffuser. The ejector assembly contains a back flow check valve.



FEATURES

The REGAL Model 210 incorporates the very best available materials with the latest technology in design and construction, to reduce maintenance, simplify construction and improve operation.

APPLICATION

The Model 210 is designed to handle the vast majority of water treatment requirements.

CAPACITIES

Dual scale metering tubes with maximum capacities of 4, 10, 25, 50 and 100 pounds per 24 hrs. of chlorine gas with corresponding metric scales of 75, 200, 500, 900 and 2000 grams per hr. Minimum feed rate is 1/20th of maximum.

FLOW RATE ADJUSTMENT

Manually adjustable by means of a flow rate control valve located at the top of the flow meter. Flow rate is then regulated by a special spring-opposed diaphragm operated valve. The system is automatic. It will go off and on as the ejector water is turned off and on and will always return to the pre-set flow rate.

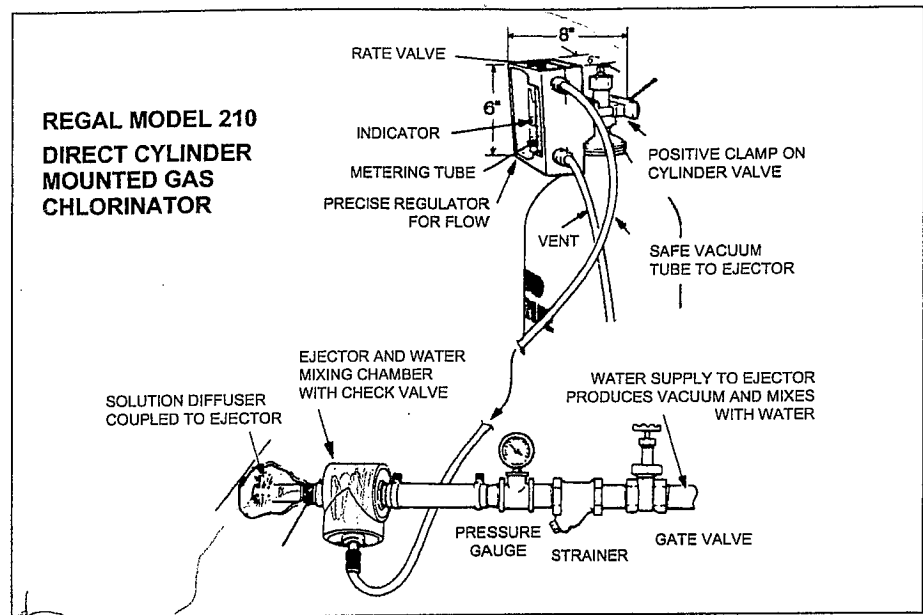

EJECTOR REQUIREMENTS

The standard ejector is designed to withstand static back pressures in excess of 200 psig (14.1 kg/cm²). However, due to the potential for "water hammer" in high pressure on-off systems and special booster pump considerations, it is recommended that a factory representative, or Chlorinators Incorporated be consulted regarding installation details on systems over 100 psig (7 kg/cm²).

The amount of water required to operate the ejector depends upon the chlorine feed rate, water back pressure and water supply pressure available. Generally, the higher the chlorine flow and higher back pressure the greater the water flow is needed.

OPERATION

The chlorinator is clamped on the chlorine cylinder valve. The ejector assembly is normally attached to the solution diffuser at the point of injection (it may be wall mounted, but this is not recommended). A vacuum line connects these two units.

Water, under pressure is forced through the ejector nozzle which creates a strong vacuum in the ejector body. This pulls gas into the ejector through a special back-flow check valve and then into the nozzle outlet. The gas mixes with the ejector water and is discharged through the diffuser into the water being treated.

The ejector vacuum is transmitted back to the chlorinator through the vacuum line; then through the rate valve and the flow meter and to the back of the diaphragm. With sufficient vacuum, the diaphragm moves backward, opening the spring loaded inlet regulating valve to allow chlorine to enter from the cylinder.

The chlorine passes through the flow rate indicating meter, flow rate adjusting valve and to the ejector.

SPECIFICATIONS

The chlorinator shall be a REGAL Model 210 manufactured by Chlorinators Incorporated, Stuart, Florida, with a maximum capacity of 100 lbs./24 hrs (2000 gms/hr). It will be a vacuum operated solution feed type and mount directly on the chlorine cylinder valve by means of a positive yoke type clamp having an integral tightening screw with slide-bar handle.

All regulating, metering, flow adjusting and safety functions shall be incorporated in the cylinder mounted unit.

The inlet safety shut-off/vacuum regulating valve shall be of capsulated construction, easily removable as a unit from the outlet side of the yoke for ease of inspection, cleaning or maintenance.

Vacuum shall be created by an ejector assembly connected directly to the chlorine solution diffuser. The assembly shall consist of a single piece venturi-recovery throat to prevent mis-alignment; also, a back flow check valve to prevent water from entering the gas system. The check valve shall be of positive, tight shut-off, unitized design not requiring springs or diaphragms for tight closing.

SERVICE

Most service problems can be handled by the user, with no special tools. If that is not possible, or desirable, the chlorinator and ejector assembly can be shipped to the factory for overhaul and retest to like-new condition for a reasonable single service charge. If the unit cannot be taken out of service, we will send an "exchange" unit.

The REGAL Model 216 Automatic Switchover Gas Chlorinator is a totally vacuum-operated system which is designed to automatically switch the chlorine feed from an empty cylinder to a full cylinder. It is also designed to provide system-backup. Should a problem develop with either vacuum regulator, chlorination can be continued. The chlorinators are of the vacuum-operated solution-feed type, designed for mounting directly on a chlorine cylinder valve. The switchovers are self-actuating, eliminating the need for a separate switchover module. A separate gas flow meter and rate control valve panel may be located wherever it is most convenient for the operator and connected between the vacuum regulator junction at the pressure relief (vent) valve, and the ejector, by means of safe vacuum tubing. The ejector assembly contains a back flow check valve. Chlorine gas flow rate is regulated by a spring-opposed diaphragm regulator which is also the automatic safety shut-off valve. Should vacuum be interrupted for any reason anywhere in the system the safety shut-off/inlet valve immediately closes, shutting off the chlorine supply from the cylinder. A pressure relief valve designed to "vent" the system also provides a central interconnection point for the vacuum tubing.

OTHER IMPORTANT FEATURES

- System Back-up — Each cylinder's chlorinator has its own vacuum regulating diaphragm and safety/inlet valve insuring that chlorination can be continued if service should be required on either chlorinator.
- Corrosion-resistant, Factory-adjusted Detent Mechanism — Detent does not require any field adjustment assuring that cylinder switchover will occur at the proper time, and that all available gas in supply cylinder will be used.
- In-Use/Stand-by Indication — Prominent indicator on face quickly tells which is the stand-by cylinder and which cylinder is in use. Optional flowmeter panels are available for applications where the feed rate must be known at the chlorinator and the flow meter/rate valve panel cannot be seen.

CAPACITIES

Dual scale metering tubes with maximum capacities of 4, 10, 25, 50 and 100 pounds per 24 hrs. of chlorine gas with corresponding metric scales of 75, 200, 500, 900 and 2000 grams per hr.

FLOW RATE ADJUSTMENT

Manually adjustable by means of a flow rate control valve located at the top of the flow meter. Flow rate is then regulated by a special spring-opposed diaphragm operated valve. The system is automatic. It will go off and on as the ejector water is turned off and on and will always return to the pre-set flow rate.

MATERIALS OF CONSTRUCTION

All materials used in REGAL gas chlorinators have been carefully chosen for their excellent corrosion-resistant, ultra-violet-resistant proper-

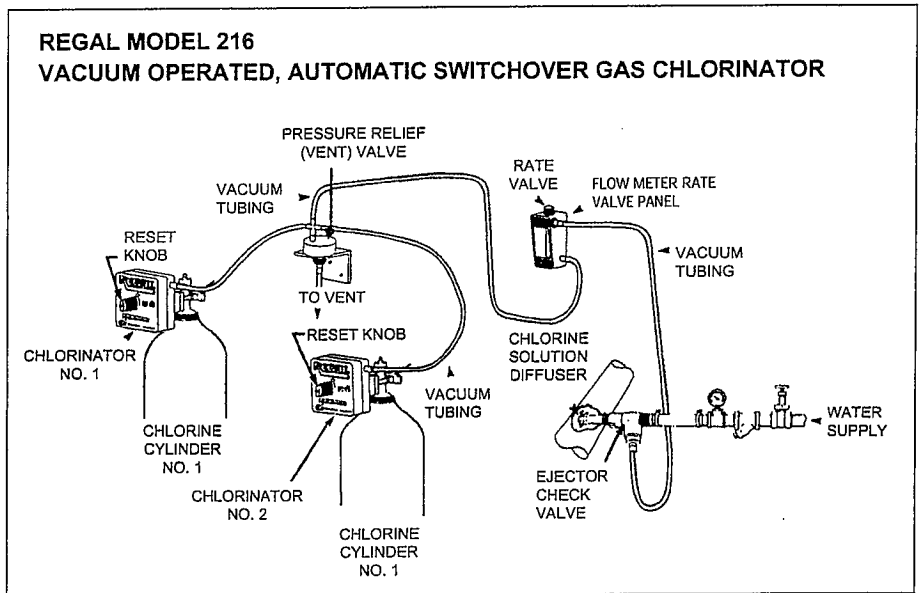

ties plus their ability to withstand stresses far greater than will be encountered in actual use.

OPERATION

The chlorinators are clamped onto the chlorine cylinder valves. The ejector assembly is normally attached to the solution diffuser at the point of injection. A vacuum line is connected from each cylinder unit to the wall-mounted, pressure-relief (vent) valve, and a single vacuum line connects the outlet of the connector to a wall-mounted, flow-meter/rate valve panel. The ejector is connected to the rate valve panel with a single vacuum line.

Water, under pressure, is forced through the ejector nozzle which creates a strong vacuum in the ejector body. This pulls gas into the ejector through a special back-flow check valve and then into the nozzle outlet. The gas mixes with the ejector water and is discharged through the diffuser into the water being treated. The ejector vacuum is transmitted through the vacuum line to the rate valve and the flow meter; then through the connector on the pressure-relief (vent) valve and on to the back of the operating chlorinator diaphragm. With sufficient vacuum, the diaphragm moves backward, opening the spring-loaded inlet regulating valve to allow chlorine to enter from the cylinder. The chlorine passes through the chlorinator, the pressure-relief (vent) valve connector and the flow rate indicating meter/flow rate adjusting valve to the ejector.

When the operating cylinder starts to run out, the vacuum starts to build up in the system causing the diaphragm of the chlorinator on "stand-by" to be drawn back, overcoming a detent mechanism and opening the safety/inlet valve. This allows chlorine gas to be withdrawn from the "stand-by" cylinder to satisfy the increased system vacuum and the vacuum falls back to the operating level.

The original supply cylinder also continues to feed until it is empty, virtually assuring that there will be no interruption of chlorination

and that full use will be made of all available chlorine. This also reduces the possibility and risk of returning cylinders with some remaining gas to the supplier.

SPECIFICATIONS

The chlorinator system shall be a vacuum-operated, solution-feed type and shall automatically switch the chlorine supply from an empty cylinder to a full cylinder. It shall be REGAL Model 216 manufactured by Chlorinators Incorporated, Stuart, Florida, and shall have a maximum capacity of 100 lbs./24 hrs (2000 gms/hr).

The Model 216 Vacuum-Operated Automatic Switchover Chlorinator shall consist of the following components: Two (2) automatic switchover vacuum regulators for mounting directly on chlorine gas cylinder valves, one (1) pressure-relief (vent) valve, one (1) chlorine gas flow meter panel with rate valve, & one (1) ejector/check valve assembly.

The vacuum regulators shall mount directly onto the cylinder valve by means of a positive yoke type clamp having an integral tightening screw with slide bar handle. The main vacuum-regulating diaphragm of each chlorinator shall have a minimum operating area of 13 sq. inches in order to achieve required accuracy and repeatability of the set chlorine flow rate. All metallic bolts shall mate with metallic threaded nuts or inserts. Plastic mating threads for metallic bolts shall not be acceptable.

Each chlorinator vacuum regulator shall have its own diaphragm, safety-shutoff/inlet valve and switchover detent mechanism, thereby, allowing chlorination to continue should it become necessary to remove either vacuum regulator from service for cleaning or servicing. Switchover detent mechanism shall be made of corrosion-resistant materials and shall not require any field adjustment.

SEE CONTENTS GUIDE 210 OR 216 FOR STANDARD ACCESSORIES AND SHIPPING WEIGHTS.

 chlorinators incorporated

1044 SE Dixie Cutoff Road, Stuart, FL 34994 USA • Tel: 772-288-4854 • Fax: 772-287-3238 • www.regalchlorinators.com • E-mail: chlorinc@aol.com

© 1998 Chlorinators Incorporated Printed in USA

Pub. No. 598-3



Scaletron™ Sets The Standard In Corrosion Resistance™
Complete Line of Scales for Water and Wastewater Treatment and Industrial Applications

[Home](#) | [Company Profile](#) | [What's New](#) | [Locate a Distributor](#) | [Search](#) | [Contact](#)

[Applications Guide](#)

[150 lb. Cylinder Scales](#)

[Ton Cylinder Scales](#)

[Drum Scales](#)

[Tank & Platform Scales](#)

[IBC Tote Scales](#)

[Process Controllers](#)

[Document Downloads](#)



MODEL 5305™ HYDRAULIC SINGLE CYLINDER SCALE

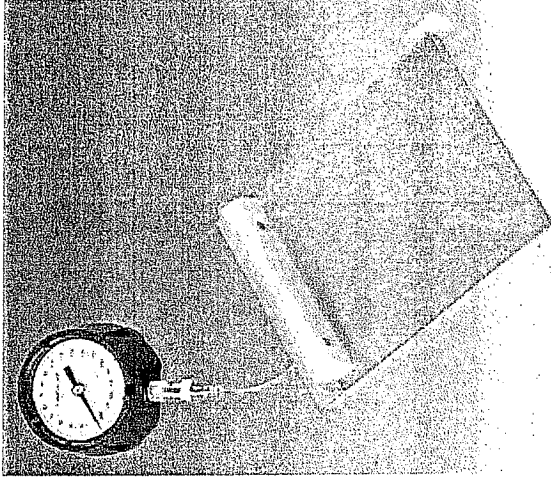

- Dependable hydraulic load cell, virtually unaffected by corrosive environments
- Wall mounted read-out dial
- Ideally suited for use in Class 1 thru 3, Div. 1, Group A thru D environments, no electric needed
- Low profile platform design increases safety and ease of cylinder handling
- Standard readability 0.5 lb/kg
- High accuracy of 1% of capacity
- Readout in pounds or kilograms
- Maintenance free UHMW pivot bearings
- Rugged steel construction protected by corrosion resistant finish, solid PVC decking.
- Measures weight of liquefied chlorine, sulfur dioxide, ammonia, hydrogen chloride, carbon dioxide, and other liquefied gases.

QUOTE ON-LINE

[Click Here for Pricing and Ordering](#)

The Model 5305™ Hydraulic Cylinder Scale provides a means of measuring the weight of liquefied gas under pressure, in order to determine a cylinder's content level. This scale is ideally suited for use in Class 1 thru 3, Division 1, Group A thru D environments because no electric power is used. It is intended for use in chlorination and other gas feeding applications. More specifically, the Model 5305 can be used to weigh liquefied chlorine, sulfur dioxide, ammonia, hydrogen chloride, or carbon dioxide packaged in cylinders.

For operation, this scale employs a hydraulic loadcell. It offers high accuracy of 1% of

capacity. Capacity ranges for each platform are as follows: Gross, 0-300 lbs (0-136 kg).



The Model 5305™ Hydraulic Cylinder Scale has a durable base which is dry powder polyester plastic coated and covered with a PVC deck. The PVC deck provides a buffer between the metal frame and cylinders to protect the frame from scratches. A rugged PVC backstop positions the cylinder for accurate weighing.

The 1.75" (44 mm) ultra-low profile platform provides added safety and ease of cylinder handling. The 4½" dial indicator is easy to read and provides tare weight adjustment. The indicator may be mounted in any convenient location; 6' of hydraulic hose is provided as standard.

Our UHMW pillow block bearings provide smooth scale operation and accurate readings, and require NO maintenance. Safety chains and sturdy wall bracket are supplied with each scale.

[General Specifications](#) **H T M L**
CLICK HERE

[Drawings](#)  [Adobe PDF](#) [Bid Specifications](#)  [Adobe PDF](#)

[Literature](#)  [Adobe PDF](#) [Operating Instructions](#)  [Adobe PDF](#)

Scaletron™ Industries, Ltd.
Bedminster Industrial Park
53 Apple Tree Lane
P.O. Box 365
Plumsteadville, PA 18949 USA

Toll Free: 1-800-257-5911 (USA & Canada)
Phone: (+1) 215-766-2670 (international)
Fax: (+1) 215-766-2672
E-mail: info@scaletron scales.com

[HOME](#) | [COMPANY PROFILE](#) | [WHAT'S NEW](#) | [LOCATE A DISTRIBUTOR](#) | [SEARCH](#) | [CONTACT](#)
[APPLICATIONS GUIDE](#) | [150 L.B. CYLINDER SCALES](#) | [TON CYLINDER SCALES](#) | [DRUM SCALES](#)
[TANK & PLATFORM SCALES](#) | [IBC TOTE SCALES](#) | [CONTROLLERS](#) | [DOCUMENT DOWNLOADS](#)